

# 2MP Mini Fixed Bullet Network Camera

IPC2122LR3-(P)F40 (60)-E



## Key Features

### Optics

- Day/night functionality
- Smart IR , up to 30 m (98 ft) IR distance
- Optical glass window with higher light transmittance
- IR anti-reflection window to increase the infrared transmittance
- 2D/3D DNR (Digital Noise Reduction)

### Compression

- Ultra 265, H.265, H.264, MJPEG
- Triple streams

### Network

- ONVIF Conformance

### Structure

- Wide temperature range: -30°C to 60°C (-22°F to 140°F)
- Wide voltage range of  $\pm 25\%$

- IP67

## Specifications

	IPC2122LR3-(P)F40-E	IPC2122LR3-(P)F60-E			
<b>Camera</b>					
Sensor	1/2.7", progressive scan, 2.0 megapixel, CMOS				
Lens	4.0mm@F1.8	6.0mm@F1.8			
DORI Distance	Lens	Detect ( m )	Observe ( m )	Recognize ( m )	Identify ( m )
	4mm	66.7	26.7	13.3	6.7
	6mm	100	40	20	10
Angle of View(H)	86.5°		55.4°		
Angle of View (V)	44.1°		30.2°		
Angle of View (O)	106.4°		68.1°		
Adjustment angle	Pan: 0°~360°		Tilt: 0°~90°		Rotate: 0°~360°
Shutter	Auto/Manual, 1/6~1/100000 s				
Minimum Illumination	Colour: 0.02 Lux (F1.8, AGC ON) 0 Lux with IR on				
Day/Night	IR-cut filter with auto switch (ICR)				
Digital noise reduction	2D/3D				
S/N	>52dB				
IR Range	Up to 30m (98 ft) IR range				
WDR	DWDR				
<b>Video</b>					
Video Compression	Ultra 265, H.265, H.264, MJPEG				
H.264 code profile	Baseline profile, Main Profile, High Profile				
Frame Rate	Main Stream:1080P (1920*1080): Max. 25 fps; Sub Stream:4CIF (704*576): Max. 25 fps;				
OSD	Up to 4 OSDs				
Privacy Mask	Up to 4 areas				
ROI	Up to 2 areas				
Motion Detection	Up to 4 areas				
<b>Network</b>					
Protocols	IPv4, IGMP, ICMP, ARP, TCP, UDP, DHCP, RTP, RTSP, RTCP, DNS, DDNS, NTP, FTP, UPnP, HTTP, HTTPS, SMTP, 802.1x, SNMP				
Compatible Integration	ONVIF(Profile S), API				
<b>Interface</b>					
Network	1 RJ45 10M/100M Base-TX Ethernet				
General	IPC2122LR3-F40(60)-E		IPC2122LR3-PF40(60)-E		
Power	12 V DC±25%		12 V DC±25%, PoE (IEEE802.3 af)		
	Power consumption: Max 5W				
Dimensions (L × W × H)	167.3 × 62.9 × 62.7 mm (6.6" × 2.5" × 2.5")				
Weight	0.26kg (0.57 lb)				
Working Environment	-30°C ~ +60°C (-22°F ~ 140°F), Humidity :10%~95% RH(non-condensing)				
Ingress Protection	IP67				

## Dimensions

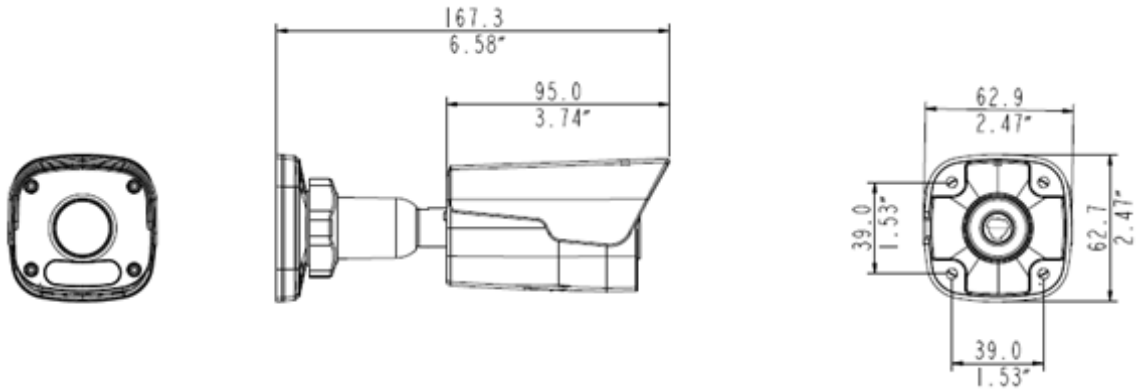

**Zhejiang Uniview Technologies Co., Ltd.**

Building No.10, Wanlun Science Park, Jiangling Road 88, Binjiang District, Hangzhou, Zhejiang, China (310051)

Email: [overseasbusiness@uniview.com](mailto:overseasbusiness@uniview.com); [globalsupport@uniview.com](mailto:globalsupport@uniview.com)

<http://www.uniview.com>

©2018 Zhejiang Uniview Technologies Co., Ltd. All rights reserved.

\*Product specifications and availability are subject to change without notice.